

D16

Pressure reducing valve with flange connection

Standard pattern

APPLICATION

According to EN 806-2 pressure reducing valves of this type protect household water installations against excessive pressure from the supply. They can also be used for industrial or commercial applications within the range of their specification.

By installing a pressure reducing valve, pressurisation damage is avoided and water consumption is reduced.

The set pressure is also maintained constant, even when there is wide inlet pressure fluctuation.

Reduction of the operating pressure and maintaining it at a constant level minimizes flow noise in the installation.

SPECIAL FEATURES

- Inlet pressure balancing – no influence on outlet pressure by fluctuating inlet pressure
- The valve insert is of high quality synthetic material and can be fully exchanged
- The adjustment spring is not in contact with the drinking water
- Easily retrofittable to convert valve to a reverse-rinsing filter combination
- The outlet pressure is set by turning the adjustment knob
- G^{1/4}" pressure gauge connections on inlet and outlet
- All materials are UBA conform

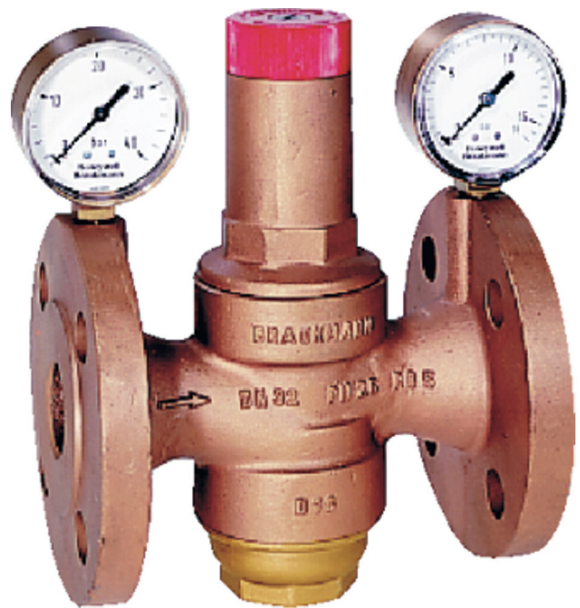

TECHNICAL DATA

Media	
Medium:	Drinking water
Connections/Sizes	
Connection sizes:	1/2" - 1 1/2"
Nominal sizes:	DN15 - DN40
Pressure values	
Max. inlet pressure:	25 bar
Outlet pressure:	1.5 - 12 bar
Preset outlet pressure:	4 bar
Nominal pressure:	PN 25
Min. pressure drop:	1 bar
Operating temperatures	
Max. operating temperature medium:	65 °C

CONSTRUCTION

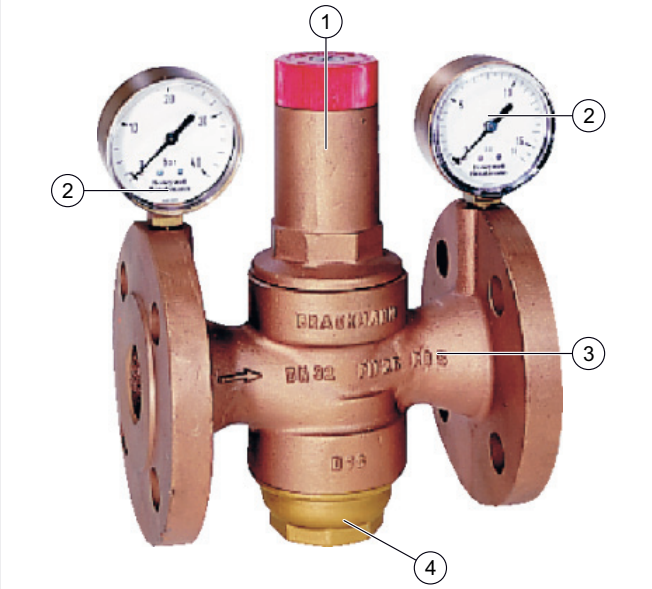
Overview	Components	Materials
	1 Spring bonnet with adjustment knob	Brass
	2 Pressure gauge not included (see accessories)	Brass
	3 Housing with PN25 flanges to DIN 86021	Red bronze
	4 Filter bowl	Brass
Not depicted components:		
	Valve insert complete with diaphragm and valve seat	High-quality synthetic material, EPDM diaphragm
	Filter with 0.5 mm mesh	Stainless steel
	Adjustment spring	Spring steel
	Seals	EPDM

METHOD OF OPERATION

Spring loaded pressure reducing valves operate by means of a force equalising system. The force of a diaphragm operates against the force of an adjustment spring. If the outlet pressure and therefore diaphragm force fall because water is drawn, the then greater force of the spring causes the valve to open. The outlet pressure then increases until the forces between the diaphragm and the spring are equal again.

The inlet pressure has no influence in either opening or closing of the valve. Because of this, inlet pressure fluctuation does not influence the outlet pressure, thus providing inlet pressure balancing.

TRANSPORTATION AND STORAGE

Keep parts in their original packaging and unpack them shortly before use.

The following parameters apply during transportation and storage:

Parameter	Value
Environment:	clean, dry and dust free
Min. ambient temperature:	5 °C
Max. ambient temperature:	55 °C
Min. ambient relative humidity:	25 % *
Max. ambient relative humidity:	85 % *

*non condensing

INSTALLATION GUIDELINES

Setup requirements

- Install in horizontal pipework with filter bowl downwards
- Install shut-off valves
- The installation location should be protected against frost and be easily accessible
 - Pressure gauge can be read off easily
 - Simplified maintenance and cleaning
- Install downstream of the filter or strainer
 - This position ensures optimum protection for the pressure reducing valve against dirt
- Provide a straight section of pipework of at least five times the nominal valve size after the pressure reducing valve (in accordance with EN 806-2)
- Requires regular maintenance in accordance with EN 806-5

Installation Example

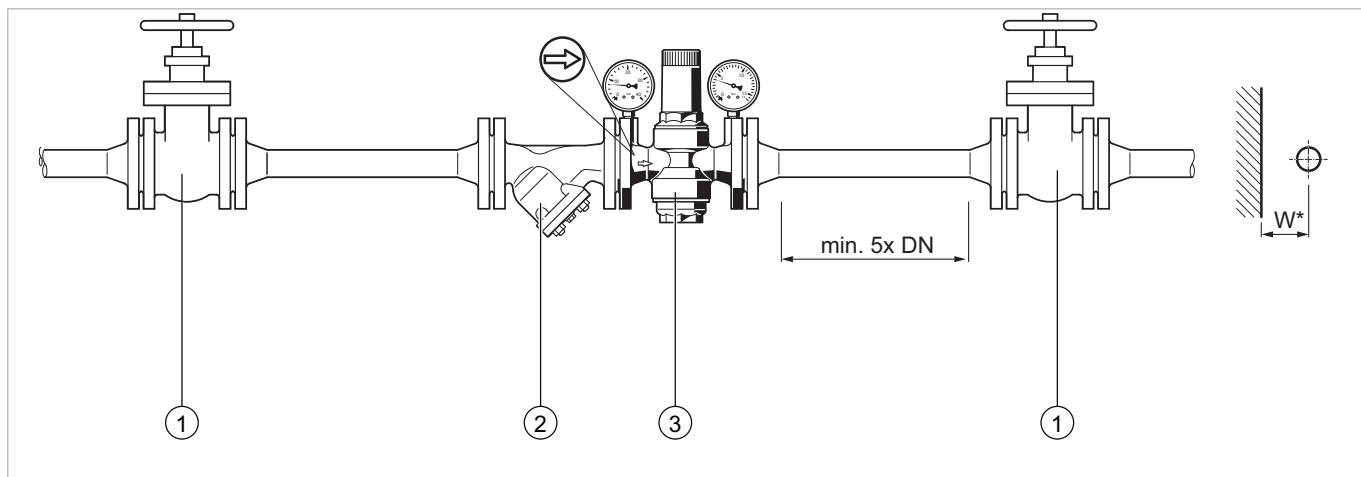

Fig. 1 Standard installation example for the pressure reducing valve

- 1 Shut-off valve
- 2 Strainer
- 3 Pressure reducing valve

Connection sizes:	15	20	25	32	40
Distance in mm (W*):	55	60	65	80	90

* Required installation distances between the centerline of the pipework and the surrounding in dependency of the connection size.

TECHNICAL CHARACTERISTICS

kvs-Values

Connection sizes:	15	20	25	32	40
k _{VS} -value (m ³ /h):	3.0	3.3	8.5	10.1	13.5

Pressure drop characteristics

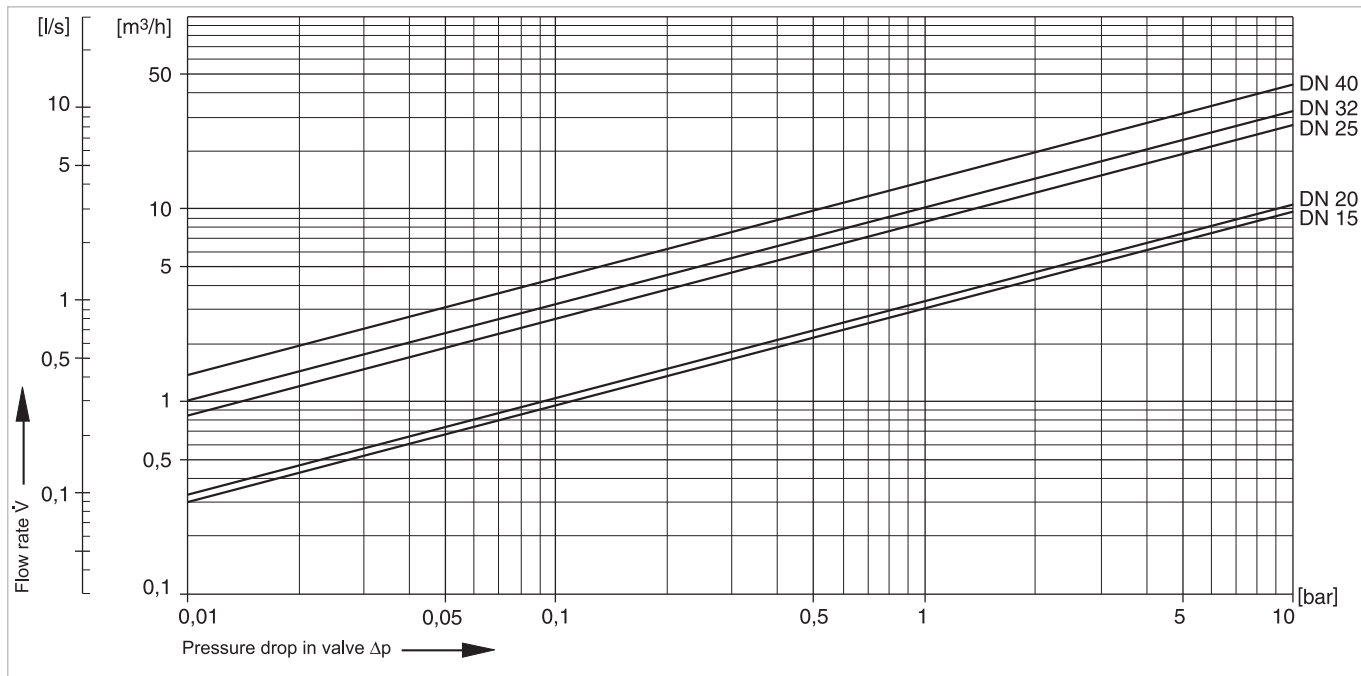
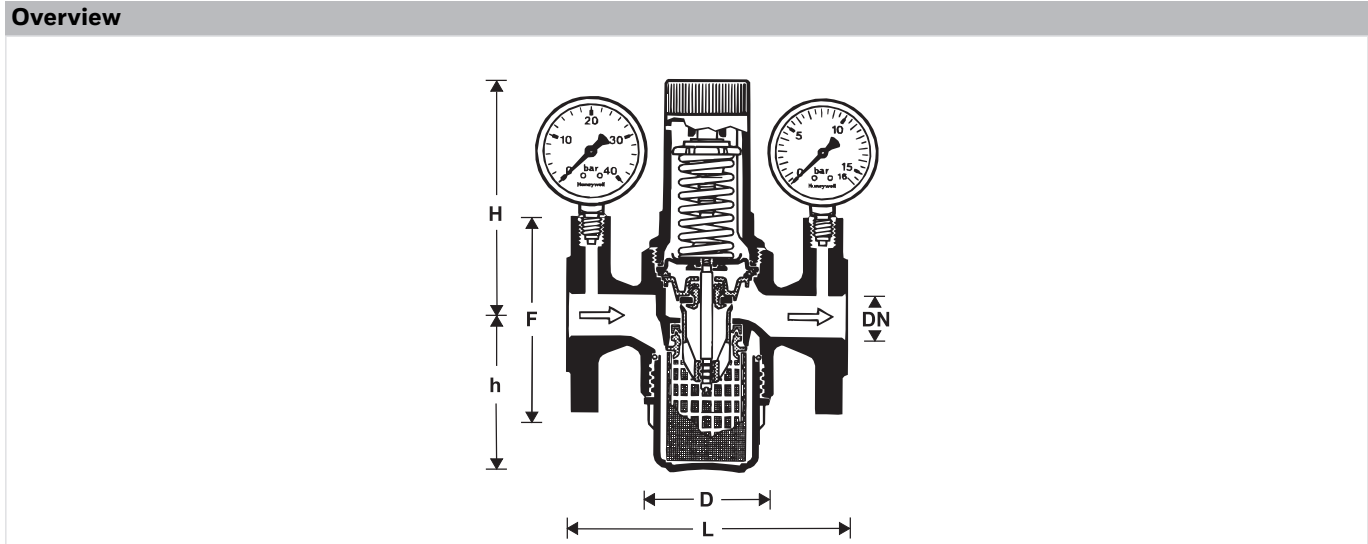

Fig. 2 Pressure drop within the valve in dependency of the flow rate and the used connection size

DIMENSIONS



Parameter	Values					
Connection sizes:	DN	15	20	25	32	40
Weight:	kg	2.9	3.6	5.6	7.5	9.5
Dimensions:	L	130	130	160	180	200
	H	103	103	140.5	140.5	172
	h	51.5	51.5	77	77	114.5
	D	56	56	74	74	85
	F	95	95	115	140	150

Note: All dimensions in mm unless stated otherwise.

ORDERING INFORMATION

The following tables contain all the information you need to make an order of an item of your choice. When ordering, please always state the type, the ordering or the part number.

Options

The valve is available in the following sizes: DN15, DN20, DN25, DN32 and DN40.



- standard
- not available

		D16-...A
Connection type:	With PN 25 flanged connections to DIN 86021	•

Note: ... = space holder for connection size

Note: Ordering number example for 1/2" and type A valve: D16-1/2A

Accessories

	Description	Dimension	Part No.
	M38K Pressure gauge Housing diameter 50 mm, below connection thread G 1/4" Note: Please indicate upper value of pressure range when ordering.		
		Range: 0 - 4 bar	M38K-A4
		Range: 0 - 10 bar	M38K-A10
		Range: 0 - 16 bar	M38K-A16
		Range: 0 - 25 bar	M38K-A25
	ZR06K Double ring wrench For removal of spring bonnet and filter bowl		ZR06K

Spare Parts

Pressure Reducing Valve D16, from 1983 onwards

Overview	Description	Dimension	Part No.
	1 Valve insert complete	DN15 + DN20	D16A-15
		DN25 + DN32	D16A-25
		DN40	D16A-40
	2 Hexagon-plug with copper sealing-ring R¹/₄" (5 pcs.)	DN15 - DN40	S06M-1/4
	3 Replacement filter insert	DN15 + DN20	ES16-15
		DN25 + DN32	ES16-25
		DN40	ES16-40
	4 O-ring set (10 pcs.)	DN15 + DN20	0901246
		DN25 + DN32	0901247
		DN40	0901248
	5 Brass filter bowl with O-ring	DN15 + DN20	SM06T-1/2
		DN25 + DN32	SM06T-1A
		DN40	SM06T-11/2

Environmental & Energy Solutions

Honeywell GmbH
 Hardhofweg
 74821 MOSBACH
 GERMANY
 Phone: (49) 6261 810
 Fax: (49) 6261 81309
<http://ecc.emea.honeywell.com>

Manufactured for and on behalf of the
 Environmental and Combustion Controls
 Division of Honeywell Technologies Sàrl, Z.A.
 La Pièce 16, 1180 Rolle, Switzerland
 by its Authorised Representative Honeywell GmbH
 ENOH-1005GE23 R0916
 Subject to change
 © 2016 Honeywell GmbH

